

InduEye® VibroSense 3

User Manual

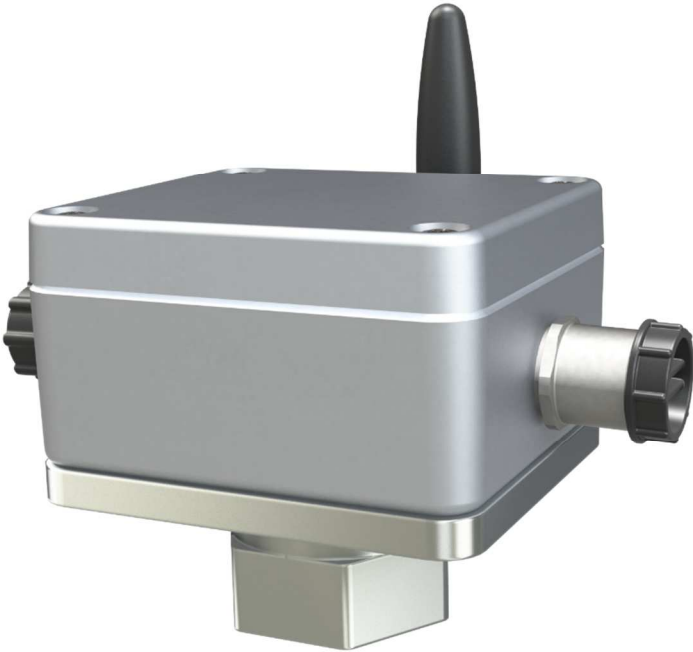

AEInnova
Alternative
Energy Innovations

Contents

1	Introduction	4
1.1	Regarding this manual	4
1.2	Safety tips and warnings	4
1.2.1	Safety guidelines	4
1.2.2	Authorised personnel	4
1.2.3	Proper utilization	4
1.2.4	Warning about incorrect use	5
1.3	Model overview	5
1.4	Packing list	5
2	Product overview	6
2.1	InduEye® VibroSense 3 module	6
2.2	Module parts	7
2.3	Functionality	7
2.3.1	Measured Variables	7
2.3.2	Working areas	7
2.4	Network configuration	7
3	Installation	8
3.1	Adhesive mounting (standard)	8
3.2	Motor fin mounting (optional)	11
3.3	Measuring position	12
3.4	Powering the IIoT Wireless module and Sensor with the energy generation module	13
3.4.1	Preparing the connection	13
3.4.2	Physical connectivity	13
3.4.3	InduEye® VibroSense 3 module Start-up	16
3.5	Powering the module with external DC power	17
3.6	Powering multiple InduEye® VibroSense 3 modules (optional)	18
3.7	Temperature sensor connection (optional)	19
4	Servicing, diagnostics, and maintenance	21
4.1	Maintenance	21
4.2	Troubleshooting	21
5	Warranty	22
6	Technical data	23
6.1	Functional features	23
6.2	Physical features	23
6.3	Working conditions	24
6.4	Electrical Features	24
6.5	Vibration sensor features	24
6.6	Temperature sensor features	25
6.7	Wireless features	26

6.8	Regulatory compliance declarations	27
6.9	Dimensions	27
7	Regulatory compliance statements and marking.....	28

Release date: 2026-03-24



Safety Instructions for Ex Zones:

For Ex applications, it is essential to follow the specific Ex safety instructions provided. These instructions are included as documentation with each module carrying Ex certification and are an integral part of the user manual.

1 Introduction

1.1 Regarding this manual

This manual provides all the necessary information for assembly, connection, and configuration as well as important instructions for maintenance and user safety.

This manual should be provided to the end user.

All rights reserved. No part of this manual may be reproduced in any form without Alternative Energy Innovations S.L. written permission.

Alternative Energy Innovations S.L. makes no warranty of any kind regarding this manual, including, but not limited to, implied warranty of merchantability and fitness for a particular purpose.

If any question arises, errors are found, or if any information is missing from this manual, please contact Alternative Energy Innovations S.L. for further information.

The specifications covered by this manual are limited to those for the standard type under the specified model number breakdown and do not cover custom-made instruments.

Please note that changes in the specifications, construction, or component parts of the module may not immediately be reflected in this manual at the time of change, given postponement of revisions will not cause difficulty to the user from a functional or performance standpoint.

1.2 Safety tips and warnings

1.2.1 Safety guidelines

This module conforms with all relevant regulations and norms. Ensure the module is in a perfect technical condition before its use. The operator is responsible for ensuring that module functions properly. When dealing with highly aggressive or corrosive substances that might cause a dangerous situation if the module fails, the operator must take adequate procedures to guarantee the unit is operational.

The user must follow the safety recommendations in these operating instructions manual, the national installation requirements and the applicable safety regulations and accident prevention rules.

For safety and warranty compliance, only authorized personnel are permitted to conduct intrusive maintenance on the module, as outlined in the operating manual. Unauthorized modifications or alterations are strictly prohibited. Additionally, only manufacturer-recommended accessories should be utilized for safety reasons.

To avoid any danger, the safety approval markings and safety tips on the module must also be observed.

1.2.2 Authorised personnel

All operations described in this documentation must be carried out only by qualified personnel authorised by the plant operator.

The required personal protective equipment must always be worn when working on and with the module.

1.2.3 Proper utilization

The InduEye® system is powered by renewable energy modules and utilizes the LoRaWan protocol for IIoT monitoring, transmitting data to a gateway. Detailed information on its application area can be found in the "Product overview" chapter. Operational reliability is contingent on adhering to specifications outlined in the operating manual and any supplementary instructions.

1.2.4 Warning about incorrect use

The supplier is not responsible for any damage caused by improper installation, incorrect technical conditions and improper use of equipment.

Do not attempt to disassemble or modify the equipment yourself. The equipment has no useful parts for the user.

Make sure that the temperatures do not exceed the recommended values.

1.3 Model overview

Reference	Model
NOD-0002	InduEye® VibroSense 3 LoRa Ex ic
NOD-0009	
NOD-0007/IEPLV3T	InduEye® VibroSense 3 LoRa
NOD-0008	
IEL3AS1	

1.4 Packing list

Before setting the system up, ensure that the following elements are present and in good condition. If an item does not match, please contact your dealer immediately.

- 1x InduEye® VibroSense 3
- 1x Ex-specific “Safety instructions” (with Ex versions)

2 Product overview

2.1 InduEye® VibroSense 3 module

The InduEye® VibroSense 3 module is the solution provided for accurate vibration monitoring. It integrates a high-performance 3-axis accelerometer (vibration sensor) and supports temperature measurement via an optional temperature sensor.



Figure 1.- InduEye® VibroSense 3 module

It provides a variety of module configurations and features:

- Vibration measurement.
- Temperature measurement.
- Combined Vibration and temperature measurement.
- Multiple InduEye® VibroSense 3 module connections with the same power supply line.
- Wireless output data reliability, delivering rich LoRa data, protected by state of the art industrial-grade security (when operated as part of a well-formed network).
- Simple and easy installation.
- Power configurations include a renewable energy generator module power supply as standard and external DC power as an alternative option.

2.2 Module parts

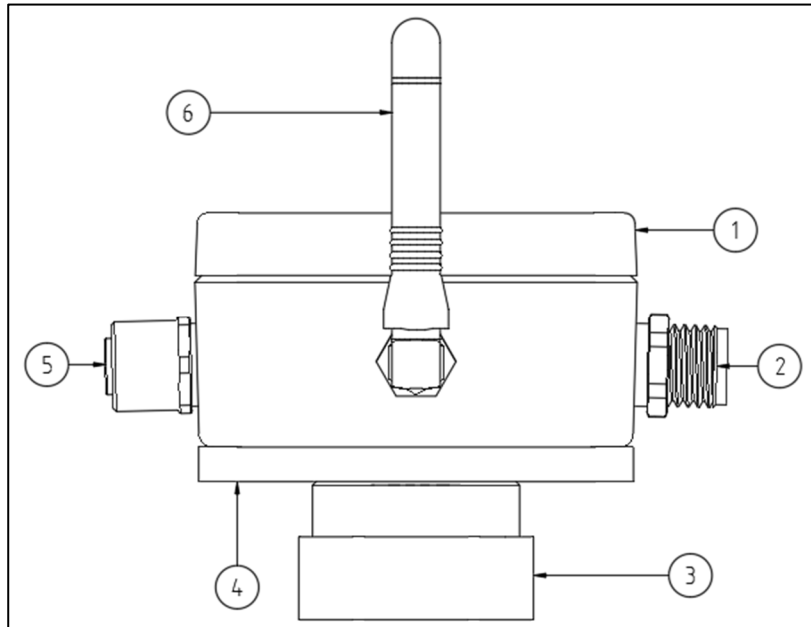

Figure 2 .- Components of InduEye® VibroSense 3 module

- | | |
|---|--|
| 1. Electronics enclosure | 2. Power supply connector |
| 3. Fixing pad | 4. Base mounting enclosure |
| 5. Temperature sensor connector. Bypass power supply option | 6. Antenna LoRa – Wireless communication |

2.3 Functionality

2.3.1 Measured Variables

Vibration: triaxial vibration, based on the International Standard **ISO 20816-1** (General guidelines) and **ISO 20816-3** (Industrial machines with nominal power above 15 kW and nominal speeds between 120 r/min and 15,000 r/min when measured in situ).

Temperature (Optional).

2.3.2 Working areas

The module is suitable for all industries.

The module is suitable for vibration measurements made on rotating, non-rotating and non-reciprocating parts of any kind of machinery. It is applicable to measure radial shaft vibration regarding the monitoring of radial clearances but excludes axial shaft vibration.

2.4 Network configuration

To configure LoRaWAN connectivity, integrate with compatible gateways, and link to the Daevis platform, please refer to the full technical manual at the following link: <https://aeinnova.com/download-center>.

3 Installation

Prior to the installation process it is recommended to follow these instructions:

- Install the Wireless Gateway and verify it is working correctly before you activate the InduEye®.
- Connect the power supply to the InduEye® VibroSense 3 module only when you are prepared to commission the module.

 CAUTION	<ul style="list-style-type: none"> • The InduEye® VibroSense 3 module protection may be compromised if not utilized following the manufacturer’s guidelines. • The InduEye® VibroSense 3 module has heat-sensitive components inside. Exposure to ambient temperatures above those specified in the section “Technical data” may reduce the lifespan of the module. • Avoid dropping, hammering or impacting the module housing before, during, or after installation. <p>Always keep in mind the following safety instructions:</p> <ul style="list-style-type: none"> • All electrical connections must be made by skilled and authorised personnel. • Only connect or disconnect in de-energized state. • When installing the module in potentially hazardous locations, ensure that the module is grounded to the machine case. • Failure to follow these installation guidelines may result in injury. • Use appropriate tools for all operations.
---	---

 NOTES	<ul style="list-style-type: none"> • Install the module where radio signals have no obstacles, avoiding walls, pipes or other emitters. • Do not install the product in a location with a corrosive atmosphere. If this cannot be avoided, ensure there is adequate ventilation.
---	--

3.1 Adhesive mounting (standard)

The module must be fixed to the surface of the machine to be monitored, using structural adhesives resistant to temperatures above 100 °C (epoxy-based, polyurethane-based, or cyanoacrylate-based structural adhesives are recommended) applied to the bottom of the fixing pad.

Procedure

1. To guarantee optimal adhesive bonding, clean the mounting surface and remove any residue or paint using a wire brush and a suitable cleaner, and proceed to degrease the adhesion area.
2. If said surface has a radius of curvature lower than 150 mm, a smooth and flat surface is required, which can be obtained by milling or polishing the surface where the fixing pad is to be placed (Figure 3). It is highly recommended to make this process to ensure a strong bond between the module and the machine to be monitored.
3. Apply a little amount of adhesive to the bottom of the fixing pad (Figure 5).
4. Determine the orientation of the axis on the machine according to the axis present on the module label (Figure 6).
5. Firmly press the fixing pad to the mounting location to remove the excess adhesive from beneath.
6. Secure the module to the surface until the adhesive can sustain its weight. Make sure the fixing pad does not slip on the adhesive.
7. Allow recommended curing time for the adhesive.
8. Proceed to install the cable connections.

<p>! NOTES</p>	<ul style="list-style-type: none"> • Although for curved surfaces larger than 150mm it is possible to install the module without machining, it is highly recommended to obtain a flat installation surface whenever possible to obtain a strong bond between the module and the machine to be monitored. • Adhesive cure time will depend on the type of adhesive used. See adhesive manufacturer's datasheet for more information.
---------------------------	---

<p>! NOTES</p>	<ul style="list-style-type: none"> • To remove the module from the machine, it is necessary to apply a debonding agent to the adhesive during the removal process. There is no universal debonding agent available due to the variety of adhesives. See adhesive manufacturer's data sheet for more information. • Another alternative for removing the module is to remove the enclosure by unscrewing it from the fixing pad by hand and supporting the fixing pad with a hexagon spanner 30 (Figure 7). This leaves only the fixing pad, which can be removed with a careful lateral strike.
---------------------------	---

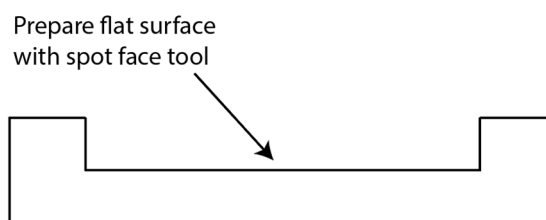

Figure 3.- Flat surface for fixing pad

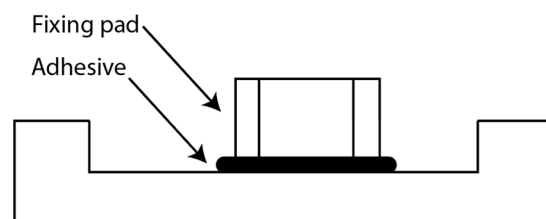

Figure 4.- Adhesive applied on the fixing pad

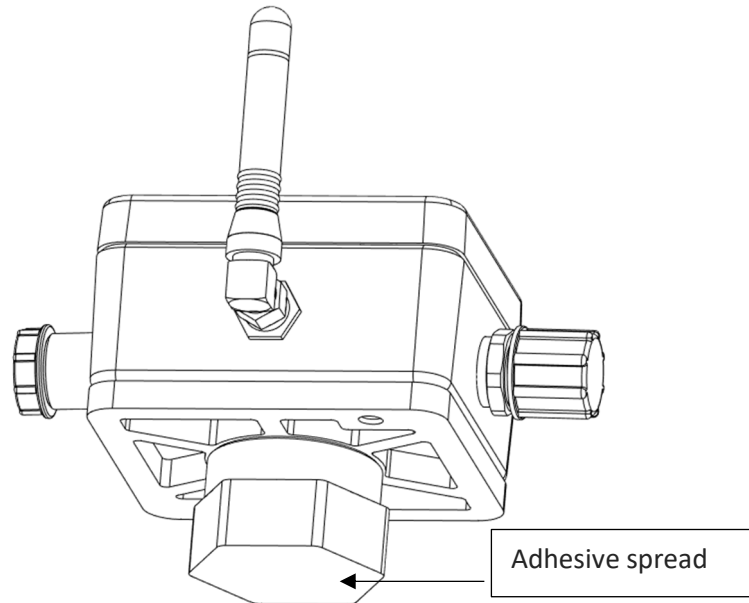

Figure 5.- Application of the glue on the fixing pad of the module

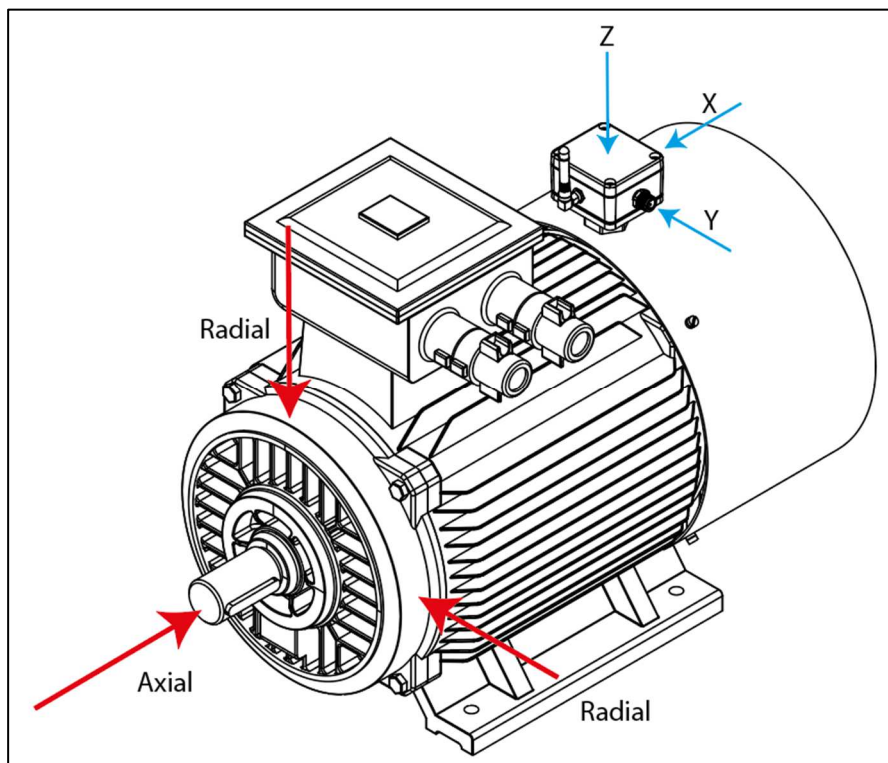

Figure 6.- Module installation – Axis orientation

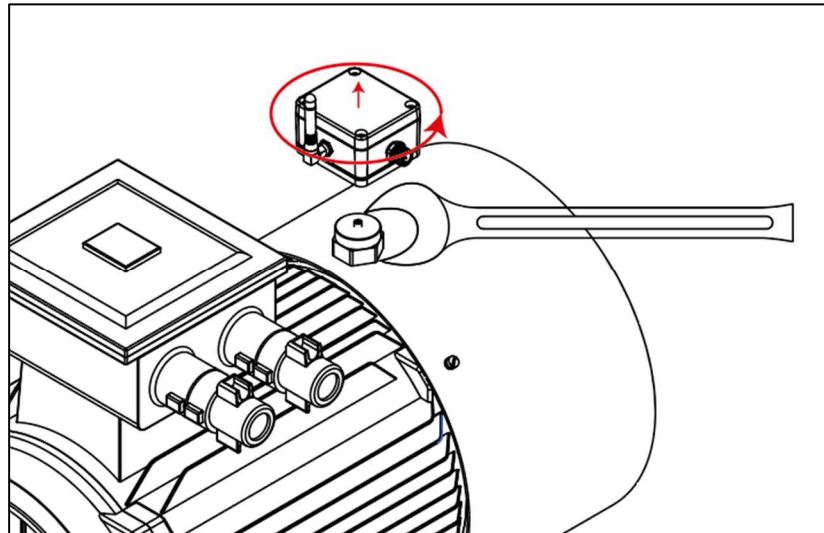

Figure 7.- Unscrewing the enclosure from the fixing pad

3.2 Motor fin mounting (optional)



Figure 8.- Motor fin mount pad

Procedure

1. Remove any paint or dirt from the motor cooling fins before installing.
2. Clean the mounting area with a degreaser spray that will not leave a residue.
3. Prepare adhesive following manufacturer's instructions.
4. Apply adhesive to the sides and the bottom of the motor fin mount pad.
5. Place the motor fin mount pad between the motor fins at the appropriate location.
 - a. The mount pad must fit between the motor fins and contact the motor casing.
 - b. Motor fin mount pads are available for motors (available in the accessories accelerometers market) in various dimensions and heights, e.g. 12.7x31.75mm, 12.7x50.8mm, 6.35x44.45mm, 6.35x25.4mm, etc. Select the one that fits the available space between fins to reduce the amount of adhesive.
6. To transfer vibration from the motor to the sensor, press the motor fin mount pad firmly into position, ensuring that the bottom is in contact with the motor casing:
 - a. Avoid placing the motor fin mount pad on the top of the fins, since this may prevent direct contact with the motor casing (see below Figure 9, left).
 - b. The motor fin mount pad tip should be as flat as possible against the motor casing (see Figure 9).
7. When installing the fin mount pad, use a spatula to redirect any excess adhesive.

8. Fill in any residual spaces with adhesive to ensure the motor fin mount pad remains in place.
9. Secure the motor fin mount pad to the surface until the adhesive can sustain its weight. Make sure the mount pad does not slip on the adhesive.
10. Allow the adhesive to cure completely.
11. Install module following the adhesive mounting instructions.

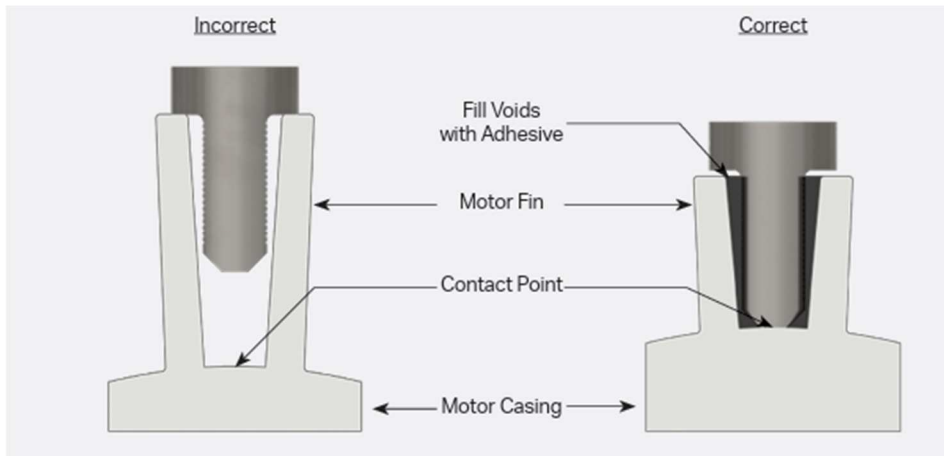

Figure 9.- Motor fin mount pad – Procedure installation

3.3 Measuring position

Non-rotating parts, such as small electric motors, bearings and support housing, should be measured to understand the total vibration of the machine as they respond to dynamic forces from rotating elements. Figure 10 and Figure 11 illustrate typical measurement sites.

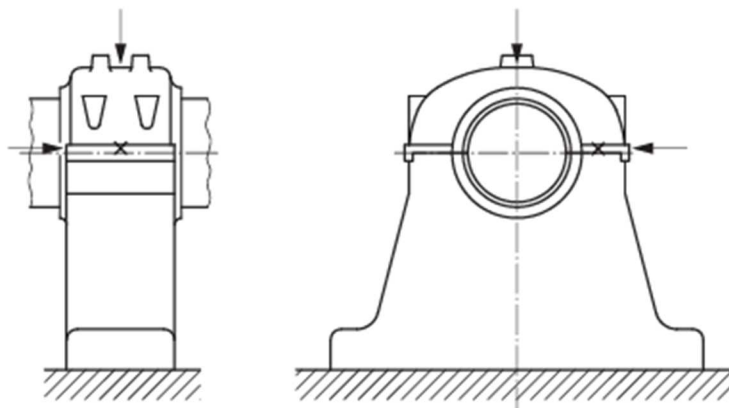

Figure 10.- Measuring points for pedestal bearings

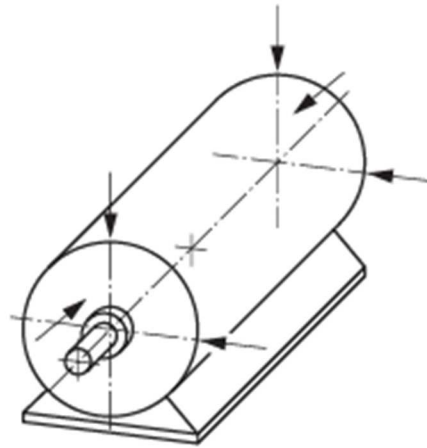



Figure 11.- Measuring points for small electrical machines

3.4 Powering the IIoT Wireless module and Sensor with the energy generation module

For typical applications, Alternative Energy Innovations' IIoT modules use renewable energy sources such as heat, air or sunlight. In this section, we use the Thermoelectric generator, a module developed by Alternative Energy Innovations S.L. to transform heat into electrical energy, as an example.

For additional information, please refer to the Thermoelectric generator module User Manual.

3.4.1 Preparing the connection

 Warning	<p>Always keep in mind the following safety instructions:</p> <ul style="list-style-type: none"> • All electrical connections must be made by skilled and authorised personnel • Only connect or disconnect the module in de-energized state.
---	---

 NOTES	<ul style="list-style-type: none"> • Refer to the chapter “Technical data” to know power supply input parameters. • Use cable with a circular cross-section. To guarantee a secure cable gland, choose the appropriate outside diameter based on the plug connection type. • Depending on the kind of power supply or signal input connection (for example, temperature), always use a cable assembly with a shielded cable and connector. • The power supply cable must only be connected to the module once it has been properly anchored.
---	--

3.4.2 Physical connectivity

The InduEye® VibroSense 3 module has been designed with safety in mind. The power supply connector is a poka-yoke so that it cannot be inserted incorrectly. If the connector does not fit properly, verify its orientation to ensure the terminal is not harmed and proceed to introduce it effortlessly.

The InduEye® VibroSense 3 module power supply connector is a M12x1 male plug, A-Code 4P circular connector, as seen in Figure 12.

 Warning	<p>All wiring should be done by a skilled electrician. Wiring must comply with all local norms and regulations. Follow local norms and regulations for wire type, size, colour, insulation voltage rating, and other parameters.</p>
--	--

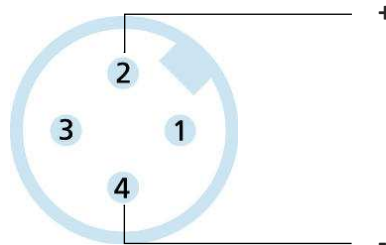

Figure 12.- InduEye® VibroSense 3 module Power supply connector M12x1, A-Code 4P – Pin configuration

Table 1.- Power supply connector pins configurations

Pin	Function
1	Not connected
2	Power supply (+)
3	Not connected
4	Power supply (-)

To supply power from the renewable power generator used such as a Thermoelectric generator (Figure 14) to the InduEye® VibroSense 3 module, the connection must be done via the power supply cable (CAB-0001) M12x1 A Code 4P Female connector.

Procedure

1. Inspect the power supply connector from the module and the cable to be inserted for any obvious signs of damage or deterioration.
2. Insert and screw the cable connection from the power generation module, in this case a Thermoelectric generator (male connector) to the InduEye® VibroSense 3 module power supply connector (female connector), as shown in Figure 13.
3. On the other side, from the power generation module, in this case a Thermoelectric generator, make sure the connection between modules is properly done (Figure 15).
4. Wait until the InduEye® VibroSense 3 module is charged, and the Gateway should start receiving data.
5. Secure the cable connection between modules to the machine 120-150mm away from the mounting location using an appropriately sized cable clamp. Do not coil the cable with a bending radius of less than 100mm (Figure 16).

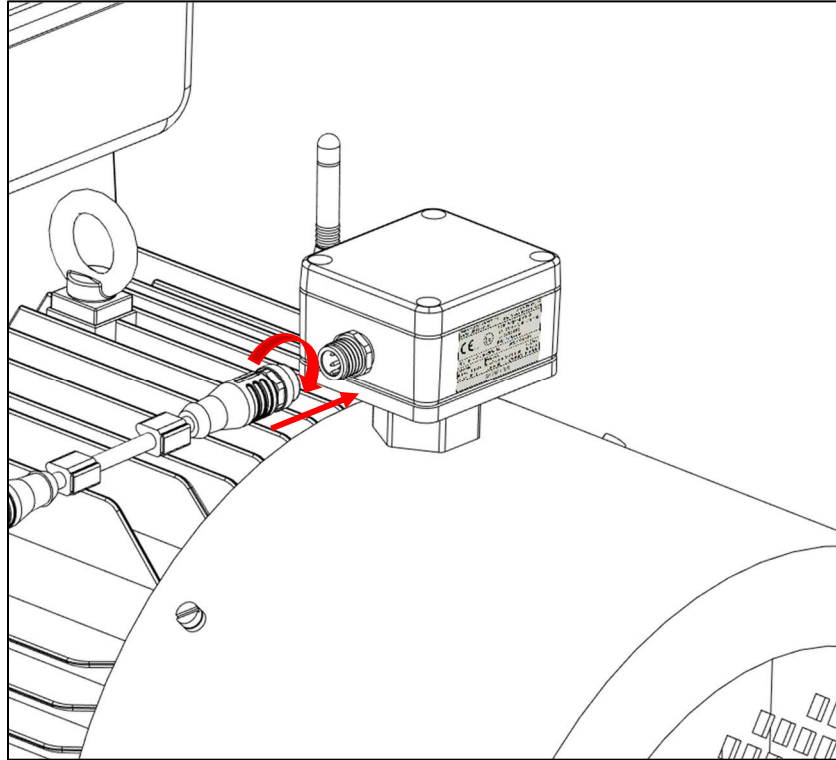

Figure 13.- Connecting the power supply to the InduEye®

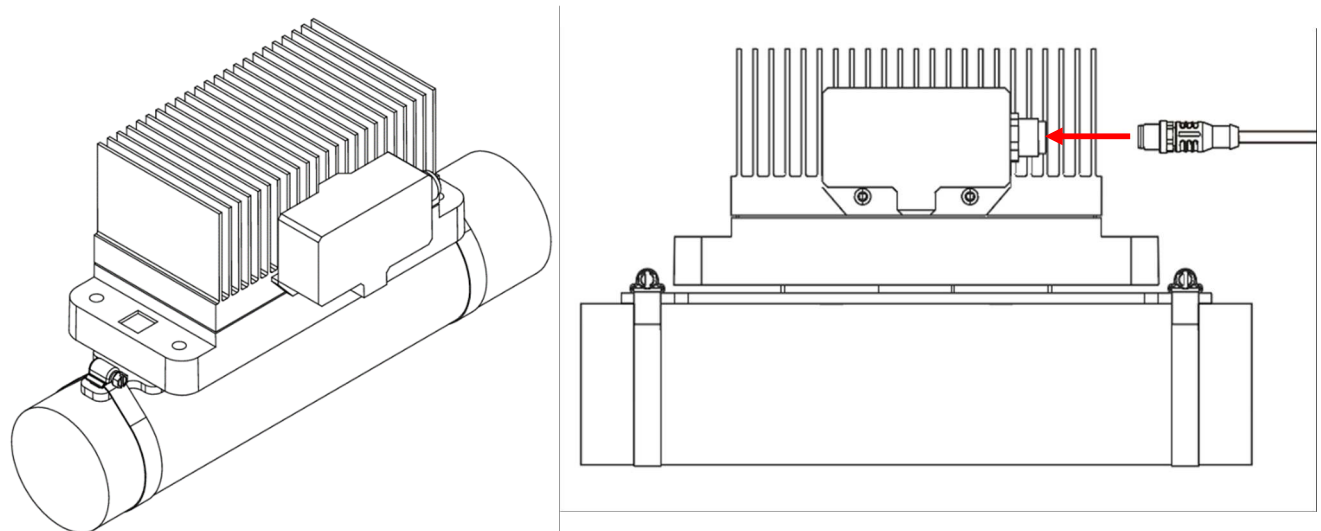

Figure 14.- Power supply (Thermoelectric generator module – Tube mounting) connection

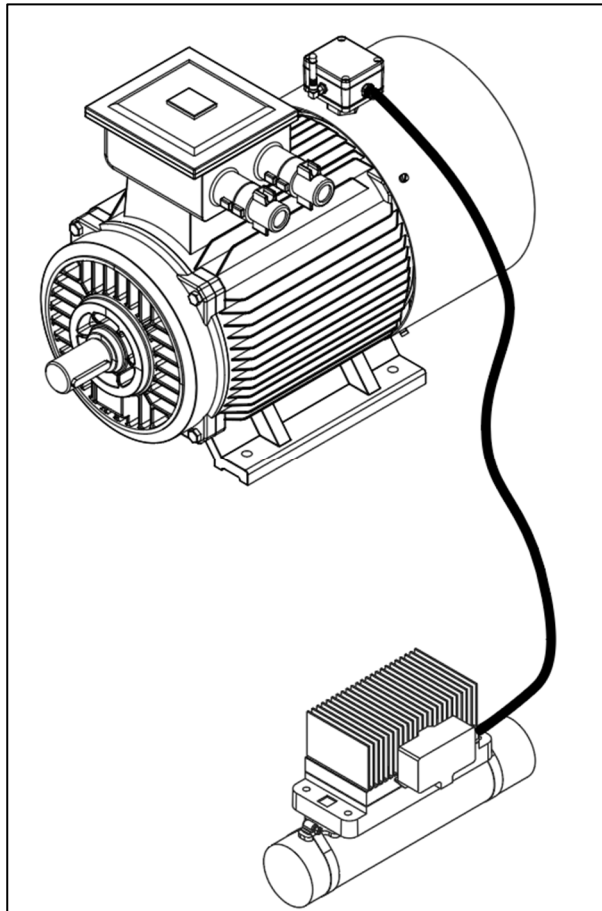

Figure 15.- Connection between InduEye® and Power supply (Thermoelectric generator module)

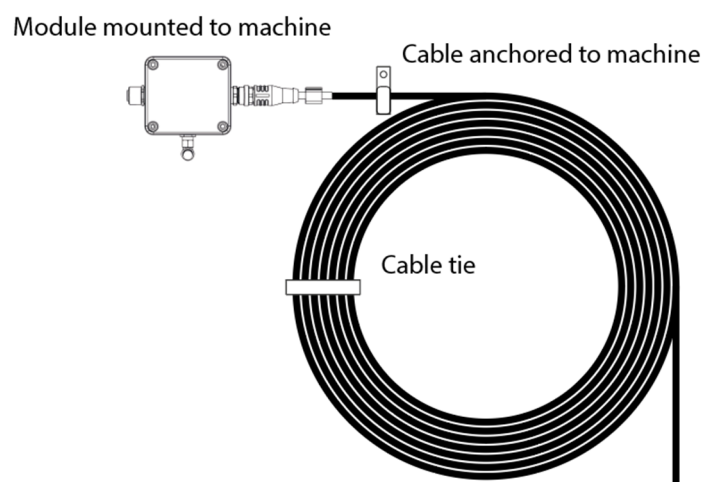

Figure 16.- Cable connection securing process

3.4.3 InduEye® VibroSense 3 module Start-up

Once the modules have been properly installed, the start-up should begin. The process unfolds as follows:

1. The Heat-intensive process starts.
2. The hot surface in contact with the Thermoelectric generator module heats up.
3. Once the hot surface reaches a temperature differential of approximately 30 °C from the ambient temperature, the Thermoelectric generator module powers the InduEye® VibroSense 3 module and starts the charging cycle.
4. After the InduEye® VibroSense 3 module is fully charged, it proceeds to transmit data to the platform.

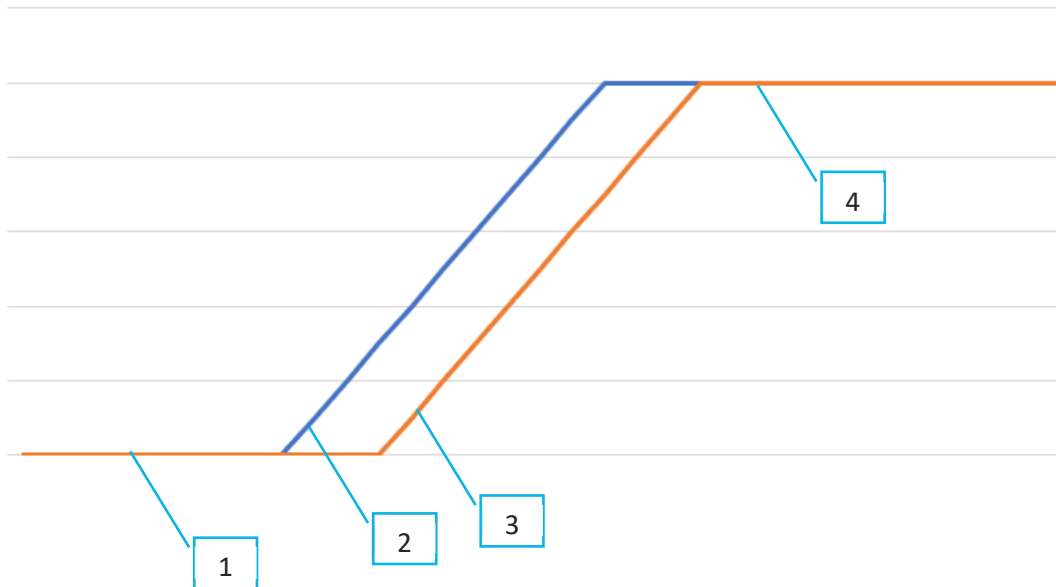

Figure 17.- Commissioning diagram (Temperature variation of the hot Surface in contact with the Thermoelectric generator module- blue line; InduEye® VibroSense 3 module charging process-orange line).

3.5 Powering the module with external DC power

The InduEye® VibroSense 3 module also has the possibility to be powered externally via a DC power supply. Refer to the chapter “Technical data” to know power supply input parameters and cable features.

The module must be supplied with external DC power via a cable with a M12x1 A-Code 4P female connection (Figure 19). If you decide to mount your own cable with an external connector (Figure 18), you must follow the pin configuration (Figure 19 and Table 1) and the mounting process described in Figure 20.

<p>! NOTES</p>	<p>You must follow the instructions and procedures described in sections 3.4.1 and 3.4.2 to power the InduEye® VibroSense 3 module.</p>
---------------------------	---



Figure 18.- Field-Wireable female connector for externally powered modules M12x1 4P, A-Code

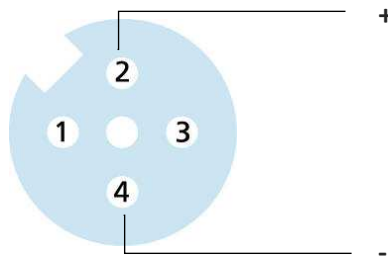

Figure 19.- Cable power supply M12x1 4P, A-Code female connector – Pin configuration

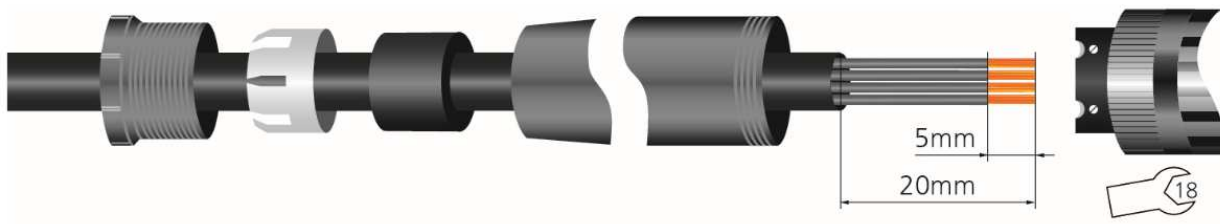



Figure 20.- Connection between cable and field-wireable connector

 Warning	<p>Even if the equipment is protected, none of its connectors should be left open and unconnected.</p>
--	--

3.6 Powering multiple InduEye® VibroSense 3 modules (optional)

One of the features of the InduEye® system is that several modules can be powered simultaneously with the same power supply line as shown in the Figure 21. This is useful when you have several motors in series or close to each other in the same process.

In order to power the module and routing cables, the instructions and procedures in sections 3.4 or 3.5 shall be followed.

Use the same double-sided M12x1 4P A-Code male-female cable connector (CAB-0001) that is used for power supply to connect the InduEye® VibroSense 3 modules, as can be shown in Figure 22. The connection is made via the power connector and the temperature sensor connector or power supply bypass of each module. See InduEye® VibroSense 3 module in Figure 2.

Refer to the chapter “Technical data” to know the power supply input parameters and cable features.

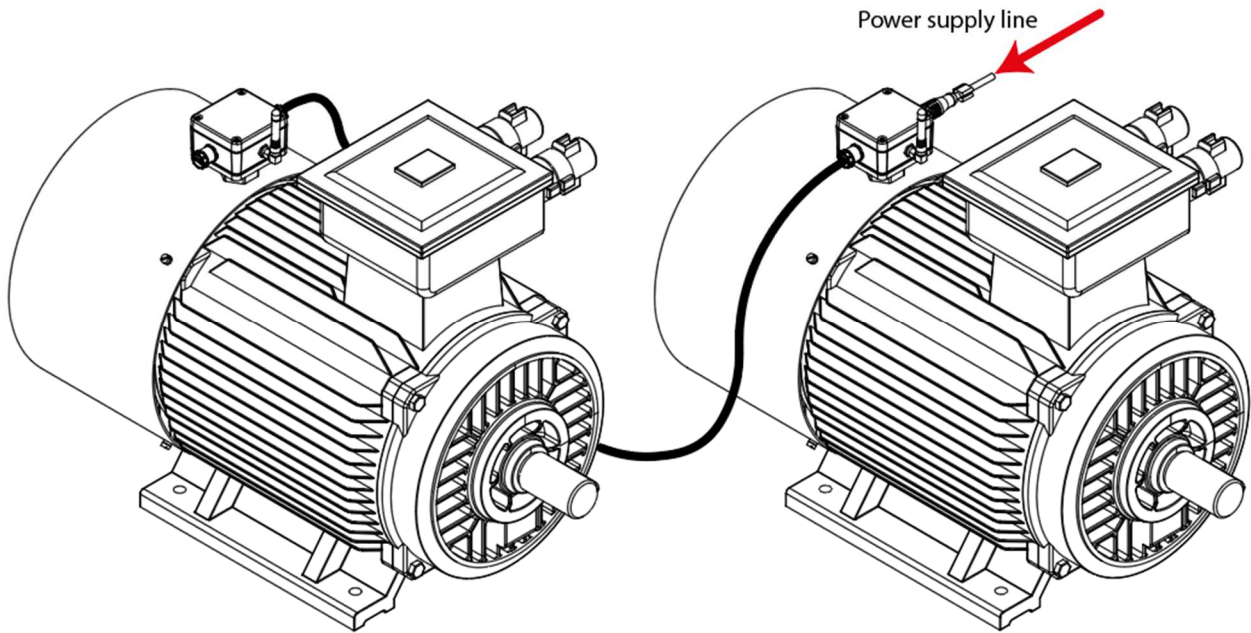

Figure 21.- Powering multiple InduEye®s with the same power supply line

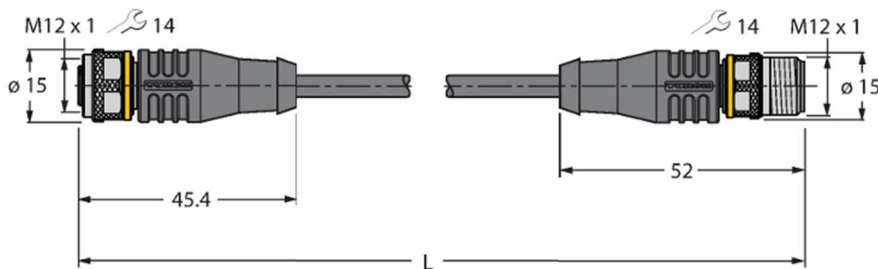

Figure 22.- Standard Male-Female cable M12x1 4P A-Code (CAB-0001) – Dimensions in mm

3.7 Temperature sensor connection (optional)

The InduEye® VibroSense 3 module can collect temperature measurements. This is achievable as the module temperature sensor connection already has an analogue input.

The temperature sensor to be connected can be a 2, 3, or 4-wire PT100 or PT1000 with shielded cable and installed on a M12x1 5P A-code male Field-Wireable connector with protective shielding.

To assure stable and reliable data transmission, attach the cable shield to the connector housing.

Depending on the number of wires of the temperature sensor, the following connection of the wires must be made on the Field-Wireable connector, as shown in Figure 23. If the temperature sensor has two wires, pins 3-4 and 1-5 of the Field-Wireable connector must be connected. If the temperature sensor has 3 wires, pins 3-4 must be connected, as shown in Figure 23 with red lines.

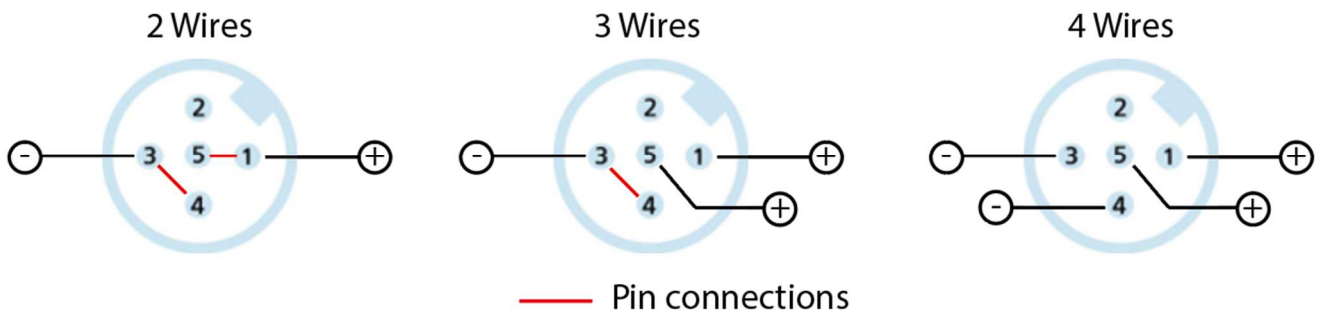

Figure 23.- Cable temperature sensor PT100/PT1000 and Field-Wireable male connector M12x1 5P A-Code – Pin configuration

4 Servicing, diagnostics, and maintenance

4.1 Maintenance

- The responsibility for the safe use of this equipment lies with the user in accordance with the provisions of these instructions for use, as well as the technical documentation of each module supplied. Proper usage of the module eliminates the need for additional maintenance during regular operation.
- It is the user's responsibility to establish an Inspection and Maintenance plan for this equipment to guarantee its proper and safe use.
- Check the module's installation and stain condition. If any module becomes dirty or dusty, wipe with a soft cloth moistened with water or mild soap.

4.2 Troubleshooting

The system operator is responsible for taking appropriate measures to correct errors.

The module provides great reliability. However, problems may develop during operation. These can be caused by the following, e.g.:

- Process
- Signal processing
- Voltage supply
- Sensor

First fault rectification measures:

- Evaluation of fault messages
- Checking the output signal
- Treatment of measurement errors

5 Warranty

- The warranty shall cover the period noted on the quotation presented to the purchaser or the purchase agreement.
- If any problems are experienced with this product, the customer should contact the Alternative Energy Innovations' representative from which this product was purchased.
- If a problem arises with this product, please inform Alternative Energy Innovations of the nature of the problem and the circumstances under which it developed, including the model specification and serial number. Any diagrams, data and other information you can include in your communication will also be helpful.
- The party responsible for the cost of fixing the problem shall be determined by Alternative Energy Innovations following an investigation conducted by Alternative Energy Innovations.

The purchaser shall bear the responsibility for repair costs, even during the warranty period, if the malfunction is due to:

- Improper and/or inadequate maintenance by the purchaser or user.
- Malfunction or damage due to a failure to handle, use, or store this product in accordance with the design specifications.
- Use of this product in a location not conforming to the standards specified by Alternative Energy Innovations, or due to improper maintenance of the installation location.
- Failure or damage due to modification or repair by any party except Alternative Energy Innovations or an approved representative of Alternative Energy Innovations.
- Malfunction or damage from improper relocation of this product after delivery.
- Reason of force majeure such as fires, earthquakes, storms/floods, thunder/lightning, or other natural disasters, or disturbances, riots, warfare, or radioactive contamination.
- Not following any of the instructions indicated in this manual, especially those mentioned in section 3.

6 Technical data

 NOTES	<p>The safety instructions included with the delivery apply to authorized modules (e.g., with Ex approval). These instructions may differ from those provided below, such as process conditions or voltage supply.</p> <p>All authorized documentation is available upon request and is supplied with the module.</p>
---	---

6.1 Functional features

Model	NOD-0002, NOD-0007/IEPLV3T, IEL3AS1, NOD-0008, NOD-0009
Input	DC input power supply.
Output	<ul style="list-style-type: none"> • Temperature (Optional) • LoRa Wireless enabled. • Vibration: RMS Velocity vibration in mm/s each axis X, Y and Z. • Power supply output for multiple InduEye® connected

6.2 Physical features

Materials	Aluminium AlSi12 (Enclosure), Stainless Steel AISI304 (Fixing Pad), CuZn – Niquel plated (Connectors), (Antenna).
Weight	415 g
Enclosure rating	IP67
Mounting	<p>Adhesive mounting with the fixing pad (standard – For more information see section 3.1).</p> <p>Motor fin mount pad (Optional – For more information see section 3.2).</p>
Input connections	<p>Input IP67 Power supply connector M12x1 4p A-Code Male (Power).</p> <p>Input IP67 temperature sensor connector M12x1 5P A-Code Female (Sensor).</p>
Output connections	Output power supply connector M12x1 4P A-Code Female (Power).
Power Cable length	2 m (standard) to 10 m (on demand).

6.3 Working conditions

Ambient temperature	-20 °C to 50 °C (-4 °F to 122 F)
Ambient humidity	0 to 95 % RH
Maximum surface temperature in contact with the module	0 °C to 70 °C with 25 °C ambient temperature.

6.4 Electrical Features

Voltage supply	5 V
Current supply	2 A
Output voltage supply	5 V (Only with input power supply connected).
Output current supply	1 A (Only with input power supply connected).
Maximum number of modules connected	Please contact AEInnova to obtain the recommended number of modules for your application.
Renewable Energy generator power supply	Yes (standard).
External DC power supply	Yes (optional).

6.5 Vibration sensor features

Precision	± 0.01 mm/S
Resolution	16 bit
Sampling rate	4 kHz (NOD-0002, NOD-0007/IEPLV3T, IEL3AS1)
	6 kHz (NOD-0008, NOD-0009)
Measurement range	± 16g
Drift from temperature	NOD-0002, NOD-0007/IEPLV3T, IEL3AS1 <ul style="list-style-type: none"> ± 0.005 %/°C
	NOD-0008, NOD-0009 <ul style="list-style-type: none"> ± 0.02 %/°C
Maximum drift at 0g in temperature	NOD-0002, NOD-0007/IEPLV3T, IEL3AS1 <ul style="list-style-type: none"> ± 0.15 mg/°C
	NOD-0008, NOD-0009 <ul style="list-style-type: none"> ± 2 mg/°C

	NOD-0002, NOD-0007/IEPLV3T, IEL3AS1, NOD-0008, NOD-0009
Measured parameters	RMS Velocity in mm/s Acceleration: <ul style="list-style-type: none"> • Peak to Peak (g) • 0 to Peak (g) • Kurtosis • Crest Factor
Axis	X, Y, Z
Measurement range	Acceleration: 0 to 157 m/s ² (0 to 16 g) Velocity: 0 to 180 mm/s
Frequency range	10 Hz to 3000 Hz (± 3 dB)
ISO 10816-3	RMS: 10 Hz–1 kHz (X, Y and Z)
Operating modes (FFT)	NOD-0002, NOD-0007/IEPLV3T, IEL3AS1: <ul style="list-style-type: none"> • NORMAL • Vibro_10_3k (default mode) • Vibro_14_100 • Vibro_100_500 • Vibro_500_1k • Vibro_1k_2k • Vibro_2k_3k NOD-0008, NOD-0009: <ul style="list-style-type: none"> • NORMAL • Vibro_10_6k (default mode) • Vibro_3k_6k • Vibro_14_100 • Vibro_100_500 • Vibro_500_1k • Vibro_1k_2k • Vibro_2k_3k
Data Sending Frequency	Up to 6 transmission/h (depending on operating mode)

6.6 Temperature sensor features

Measured parameter	Temperature in °C
Measurement range	-20 °C to 400 °C (-4 °F to 752 °F) (Depends on the temperature probe used)
Resolution	0.1 °C
Measurement element	External PT100 Probe

6.7 Wireless features

Communication Protocol	NOD-0002, NOD-0007/IEPLV3T LoRaWAN Class A EU868
	IELS3AS1 LoRaWAN Class A AS923
	NOD-0008, NOD-0009 LoRaWAN Class A EU868, AS923, AU915, US915
Antenna	External omnidirectional antenna (2 dBi max)
Data rate	5,5 kbit/s
Radio Security	AES128-bit encryption
Coverage Range	Up to 2 km
RF transmission power	EU868: max. 14 dBm AS923: max. 16 dBm AU915: max. 23 dBm US915: max. 23 dBm

* The antenna of the radio equipment must be a monopole antenna of 2dBi peak gain as supplied with the equipment (ref ANT-0001/ANT-0003, please contact Alternative Energy Innovations in case you need replacement). If the above guidelines are not met, compliance with the EN 300 220-2 v3.1.1 standard is not guaranteed.

** The antenna of the radio equipment is a monopole antenna of 2dBi peak gain as supplied with the equipment (ref ANT-0001/ANT-0003, please contact Alternative Energy Innovations in case you need replacement).

6.8 Regulatory compliance declarations

Ingress protection rating	IP67
Explosion-proof	ATEX Zone 2 and Zone 22 (NOD-0002/NOD-0009)
Certifications	<ul style="list-style-type: none"> • CE • FCC • ANATEL (Pending) • MIC (IEL3AS1)

6.9 Dimensions

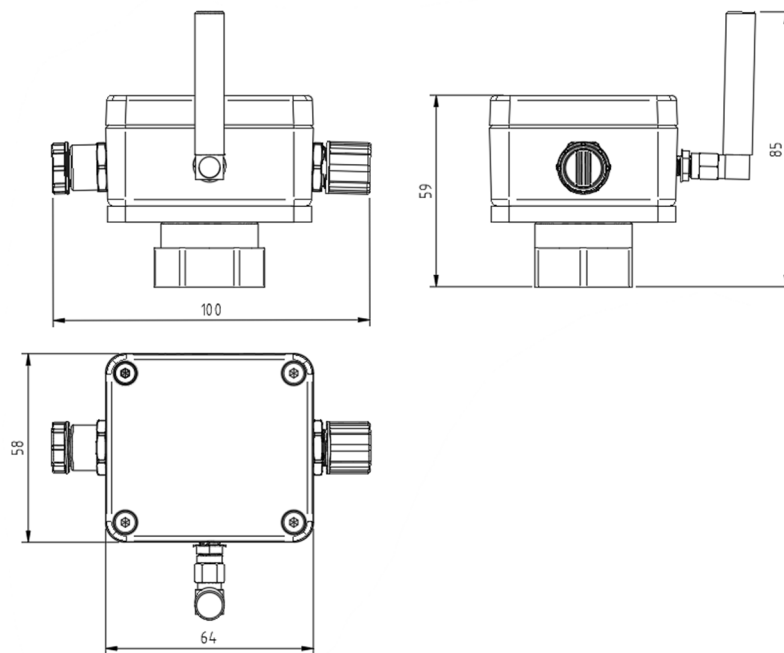

Figure 24.- InduEye® VibroSense 3 module - Dimensions in mm

7 Regulatory compliance statements and marking

Equipment with CE mark:

The equipment has been tested and complies with all relevant directives required for CE marking:

- Directive 2014/53/EU (RED) on Radio Equipment
- Directive 2014/30/UE (EMC) on Electromagnetic Compatibility
- Directive 2011/65/EU (RoHS) on Restriction of Hazardous Substances

Additionally, the InduEye® VibroSense 3 LoRa Ex modules comply with the following:

- Directive 2014/34/EU (ATEX) on equipment and protective systems intended for use in potentially explosive atmospheres.

The corresponding declaration of conformity is supplied with the product.

Equipment with FCC mark:

The equipment complies with Part 15 of the FCC Rules. Operation is subject to the following two conditions:

1. This device may not cause harmful interference, and
2. This device must accept any interference received, including interference that may cause undesired operation.

This equipment has been tested and found to comply with the limits for a Class B digital device, pursuant to part 15 of the FCC Rules. These limits are designed to provide reasonable protection against harmful interference in a residential installation. This equipment generates uses and can radiate radio frequency energy and, if not installed and used in accordance with the instructions, may cause harmful interference to radio communications. However, there is no guarantee that interference will not occur in a particular installation. If this equipment does cause harmful interference to radio or television reception, which can be determined by turning the equipment off and on, the user is encouraged to try to correct the interference by one or more of the following measures:

- Reorient or relocate the receiving antenna.
- Increase the separation between the equipment and receiver.
- Connect the equipment into an outlet on a circuit different from that to which the receiver is connected.
- Consult the dealer or an experienced radio/TV technician for help

Contains FCC ID: XMR2024KG200Z.

The antenna used with this transmitter must not be co-located or operated in conjunction with any other antenna or transmitter.

Any changes or modifications not expressly approved by the manufacturer could void the user's authority to operate the equipment.

This equipment complies with FCC radiation exposure limits set for an uncontrolled environment. To maintain compliance with FCC RF exposure guidelines, a minimum separation distance of 20 cm (8 inches) must be maintained between the antenna and all people during operation.



AEInnova

Alternative
Energy Innovations